

USER MANUAL

**LANKA[®]
GRILLS**

Modern BBQ Grill

This BBQ grill utilizes gas and charcoal as fuel.

3 Year limited warranty.

Stainless steel cooking grates (SS 304).

Charcoal grates.

Two burners.

Powder coated surface.

Temperature gauge.

⚠ THIS GRILL IS FOR OUTDOOR USE ONLY!

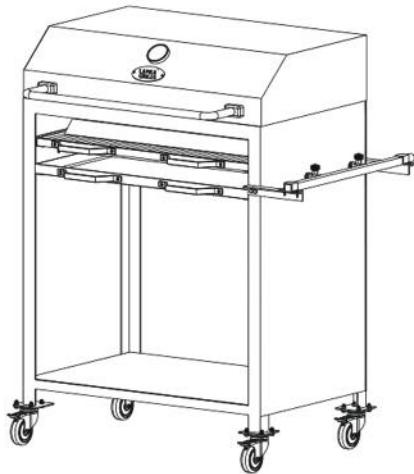

Thank you for choosing Lanka Grills product. Please read this user manual before operation to obtain insight to this product in terms of features, operation, maintenance, safety and specifications. Follow all instructions and warnings when using this BBQ Grill.

Inside the box...

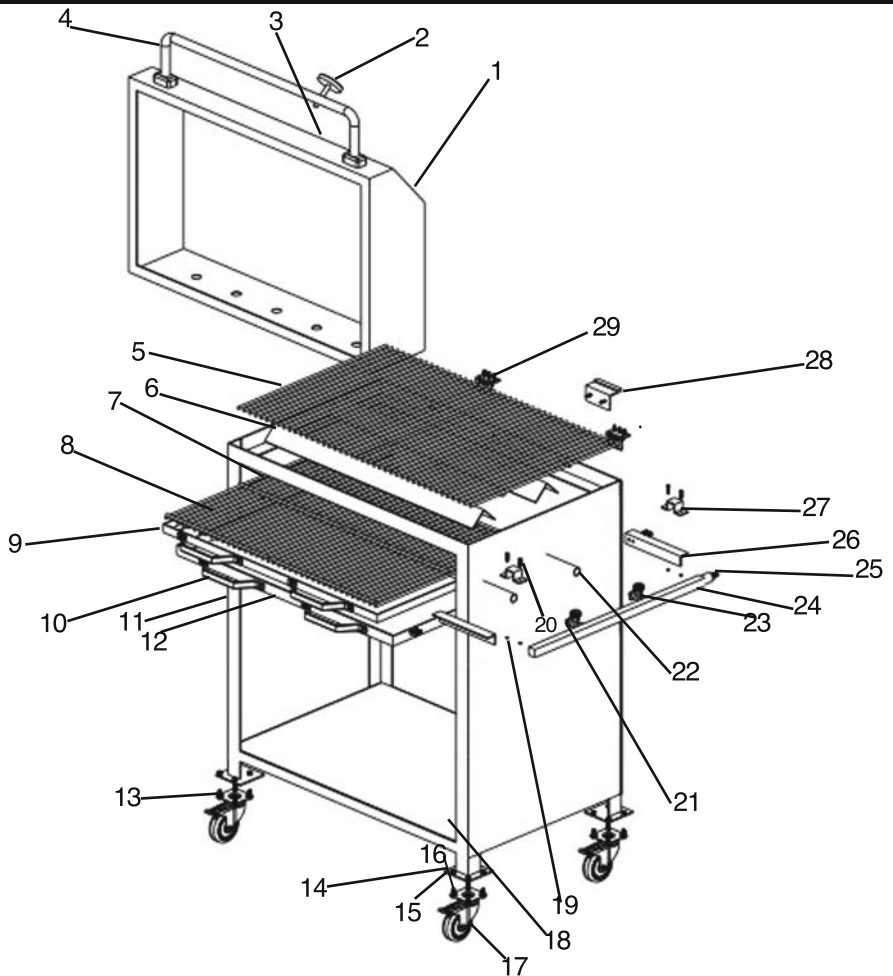

- | | | | |
|-----------------------|---------------------------|--------------------------|-----------------|
| 1 - Lid | 9 - Charcoal Grates Frame | 17 - Caster Wheel | 25 - Gas Nipple |
| 2 - Temperature Gauge | 10 - Aluminium Handle | 18 - Bottom Platform | 26 - Bracket |
| 3 - Badge | 11 - Body | 19 - Nut | 27 - Clip |
| 4 - SS Lift Handle | 12 - Drip Tray | 20 - Screw | 28 - Stopper |
| 5 - SS Cooking Grates | 13 - 6mm Bolt | 21 - Gas Tap Washer | 29 - Hinge |
| 6 - SS Heat Shield | 14 - 6mm Nut | 22 - Burner | |
| 7 - Burner Holder | 15 - 6mm Spring Washer | 23 - Gas Tap (Gas Valve) | |
| 8 - Charcoal Grates | 16 - 6mm Bolt | 24 - Gas Tube | |

Model name, part number with part name is necessary when ordering spare parts.

Assembly Guide

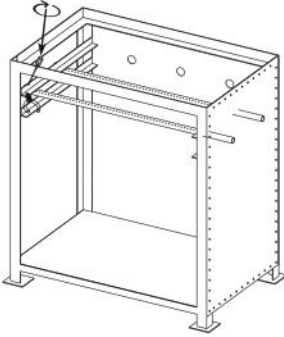

Step 1 - Fix the gas burner by tightening the screw, holding the nut through sharp nose plier.

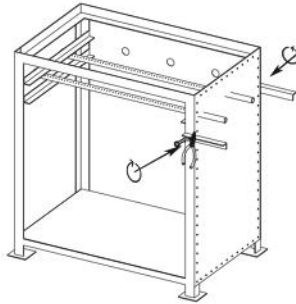

Step 2 - Fix the brackets through bolts on each sides, holding the nut inside the grill through plier.

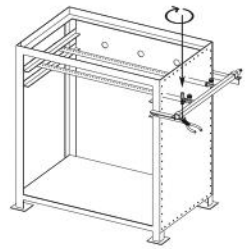

Step 3 - Fix the gas clips through 2 screws on each side by holding the nut through plier.
Part No. - 24 (Gas Tube), 23 (Gas Tap) & 25 (Gas Nipple) comes as single part. If one of them are removed or disconnected, stop assembling and contact supplier. Make sure the washer valve (P21) is inserted to Gas Tap(23).

⚠ Do Not Overtighten!



Step 4 - Fix the caster wheels accordingly by tightening the 6mm bolt facing upwards through wrench holding nut with washer on the otherside through another wrench.

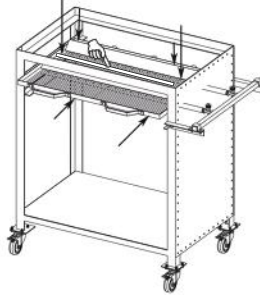

Step 5 - Insert the charcoal grates on to the charcoal tray frame. **Horizontal rod side upwards (Finger point)**(Comes as 2 Piece). Insert it to the charcoal tray rack. Place the stainless steel heat shields on top of the charcoal grates covering burner.



Step 6 - Insert the drip tray to the drip tray rack.

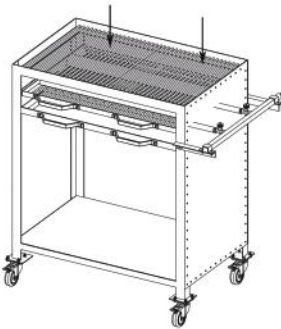

Step 7 - Place the stainless steel cooking grates on top of the grill.

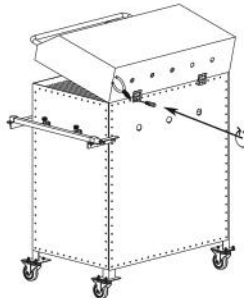

Step 8 - Fix the lid to grill body by fixing the 2x2 butt hinges to the corresponding lid holes and body holes through 4mm screws and nuts. Tighten the bolts through screw driver holding the nuts through plier.

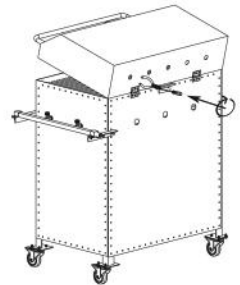

Step 9 - Fix the stopper by 4mm screws and nuts. Tighten the bolts through screw driver holding the nuts through plier.

COMES FULLY ASSEMBLED!

Assembled in 9 steps.

- Tools Needed
- 10 Size Wrench (6mm) x 2
 - Philip Head Screw Driver
 - Sharp Nose Plier
- (Tools Not Provided)



WARNING!



If you smell gas or hear a leaking noise shut off gas to the grill & call your supplier. (Failure to follow these instructions could result in severe injury, explosion, property damage or death.)



Do not store or use gasoline, alcohol or any other flammable liquids in the area surrounding the grill area.



Some parts may contain sharp edges. Wear protective gloves during operation.



The grill will be extremely hot during operation. Do not touch the surfaces of the grill while operation.



Minimum 1 inch gap between grill body and charcoal on all 4 sides are compulsory when charcoal grilling.



Do not let children under 16 years to operate this grill. Keep children and pets away from this machine at all times.



Never light the burner with lid closed, or soon after opening the lid.



Never operate this grill within 10 feet of any structure, wall and etc. Never operate within 20 feet of any flammable liquid or materials.



If a fire occurs keep away from the grill and call your fire department.



Wash the SS cooking grates before use!
Wash your hands after using this product!



Do not attempt to repair or alter any part of this product. Any modification to this assembly will revoke your warranty and create the risk of gas leaks and fire.



When grill not in use, Disconnect the gas cylinder!



Pre heat the grill for 10 minutes prior to use. Curing of coating will produce an odour on first time.



Clean the product more often. Do not wash using high pressure water. Wiping the surface through wet cloth, atleast 3 hours after usage is recommended. Make sure there are no bristles on the cooking grates before grilling.



If the flame is blocked in particular holes of the burner, use a pin to clean up the blocks in holes. If the burner is hard to light, remove the burner and clean inside. (Long Wire brush & Blower)



Never use the grill indoor! Always use it outdoor in a very well ventilated space.



Do not use high pressure gas regulator! Low pressure gas regulator is recommended.



The LP gas cylinder should never be stored in an area where temperature can reach 125°F. (51°C)



Do not ignite the burner using match sticks, paper or other materials. Use a BBQ lighter to ignite the burner.



If ignition doesn't occur in 5 seconds after switching on the gas control knob, remove the gas cylinder and contact the supplier.

FOR OUTDOOR USE ONLY!

STARTUP GUIDE

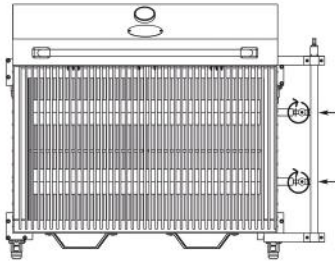

Step 1 - Make sure the gas valves are fully closed (Clockwise) and open the lid.

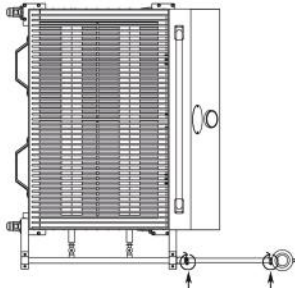

Step 2 - Insert the hose in gas inlet and regulator and tighten the hose clips on both side.

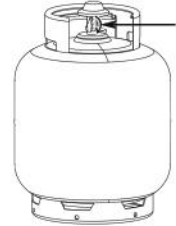

Step 3 - Connect the regulator to gas cylinder and switch on. (Rotate Clockwise)
[Conventional Low Pressure Gas Regulator is Recommended]

⚠ Do Not Use High Pressure Gas Regulator!

GAS GRILLING

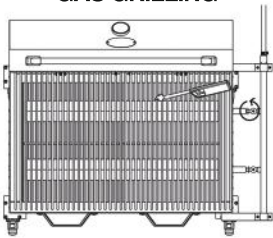

Step 4 - For Gas grilling, start the lighter, point towards the burner (Under SS Heat Shield) and open the gas valve slowly to ignite the burner. (Anticlockwise)
Control the fire using gas valves.

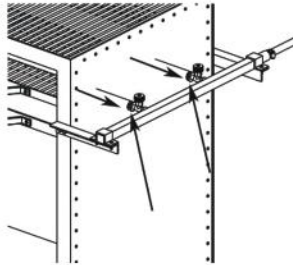

Step 5 - Release the washer valve away from the burner for more air intake, hence less carbon emission. (Flame Colour - Light Blue)

CHARCOAL GRILLING

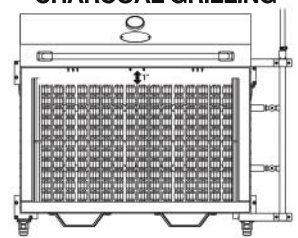

Step 6 - For Charcoal grilling, remove the SS heat shield and pour charcoal on the charcoal grates. (Black Grates) Avoid positioning the charcoal to the edge of the charcoal grates. 1" gap between body & charcoal is compulsory.

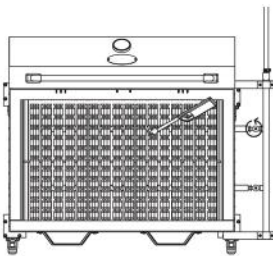

Step 7 - Start the lighter, point towards the burner and open the gas valve (anticlockwise) to ignite the burner. Charcoal will be lit by this method.

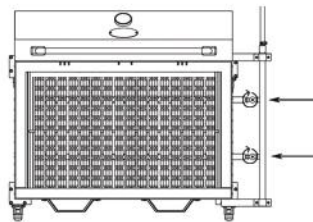

Step 8 - Once charcoal is lit or Gas grilling is finished, Turn off the gas valve fully. (Rotate Clockwise)





Step 9 - Remove the gas regulator from the Gas Cylinder.

Grill Maintenance

- Allow the grill to cool before cleaning.
- When cleaning the grill, cover the area, brush out the residues and ash and wipe the body with wet cloth.
- SS Cooking grates may be cleaned with wire brush, rinse with water and air dry before cooking again. (make sure there's no loose bristles on the cooking grates after cleaning).
- Apply oil to hinges once every 3 months to ensure smooth operation.
- Use a grill cover to cover the grill when it's exposed to extreme weather conditions. This will increase the life time of the grill.
- Discoloration of burners & charcoal grates are common since they're exposed to direct flame.

 **Lid must be opened slowly and rested.** Fastly opening and throwing the lid will cause broken hinge.

 Minimum gap of 1 inch between charcoal & grill body on all 4 sides are compulsory! (Charcoal Grilling)

 Clean the meat drippings (fat) & charcoal ash from the machine, grates and grill body & Dispose the wastages from drip tray after each cooking. Failure to do so could cause a grease fire. (Extreme rise of flame height), Hence **discoloration of powder coating**.

 Do not pour any liquid (liquor, alcohol, wine, drinks & etc.) inside the grill while grilling. This will cause explosion!

 Attempting to light burner with lid closed may cause an explosion, hence serious injuries. Do not expose any part of your body or clothing above cooking area when lighting.

 Do not close or cover the ventilation holes or the exhaust pipe. Closing holes or pipe may cause explosion.

Grill Care & Use

Limited Warranty

This warranty only applies to units purchased from an authorized retailer.

A dated sales receipt **WILL** be required for warranty service.

This limited warranty applies only to the functionality of the product and **does not cover** cosmetic issues such as dents, scratches, powder coating peel off, corrosions or discoloring by heat, abrasive and chemical cleaners or any tools used in the installation or assembly of the product, surface rust, or the discoloration of stainless steel surfaces. Powder coating is not warranted and will require touch up. **RUST** is not considered a manufacturing or materials defect.

MANUFACTURER WILL NOT PAY FOR:

1. Transport cost for warranty and replacement parts
2. Damage, failures, or operating difficulties resulting from accident, alteration, careless handling, misuse, abuse, fire, improper installation or maintenance, use of products for installation not approved by the manufacturer.
3. Any food loss due to product failures or operating difficulties.
4. Pickup and delivery of your product.
5. Repairs to parts resulting due to unauthorized modifications made to the product.
6. The removal or reinstallation of your product

Dealers, retailers or any others selling this product **do not have any authority** to make any additional warranties or promises in addition to or inconsistent with those stated above.

Manufacturer's maximum liability at any event, **will not exceed** the purchase price of the product paid by the original customer.

The warranty will expire, 3 years from the date of purchase.

3 Year Limited Warranty

Scan the QR code below to watch the video on Startup Guide.



YouTube Link -<https://www.youtube.com/watch?v=gzQxBEQvQDU>

LANKA[®]
GRILLS

www.lankagrills.lk
info@lankagrills.lk

© Designed and Manufactured by Lanka Grills.
No.581, Negombo Road, Wattala.

©This product is protected under the National Intellectual Property Office of Sri Lanka.