

# USER MANUAL

**LANKA<sup>®</sup>**  
**GRILLS**

## Dynamic Grill

This BBQ grill utilizes gas and charcoal as fuel.

3 Year limited warranty.

Stainless steel cooking grates (SS 304).

Charcoal grates.

Two burners.

Powder coated surface.

Stainless steel heat shields.

**⚠ THIS GRILL IS FOR OUTDOOR USE ONLY!**

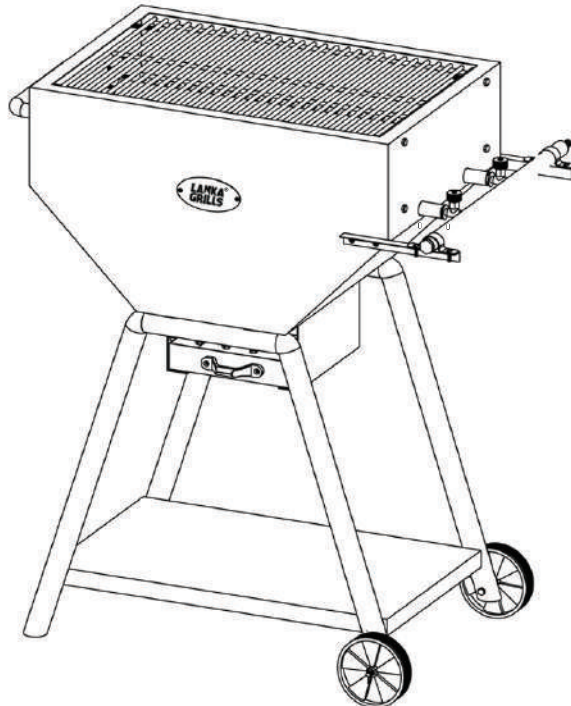

Thank you for choosing Lanka Grills product. Please read this user manual before operation to obtain insight to this product in terms of features, operation, maintenance, safety and specifications. Follow all instructions and warnings when using this BBQ Grill.

# Inside the box...

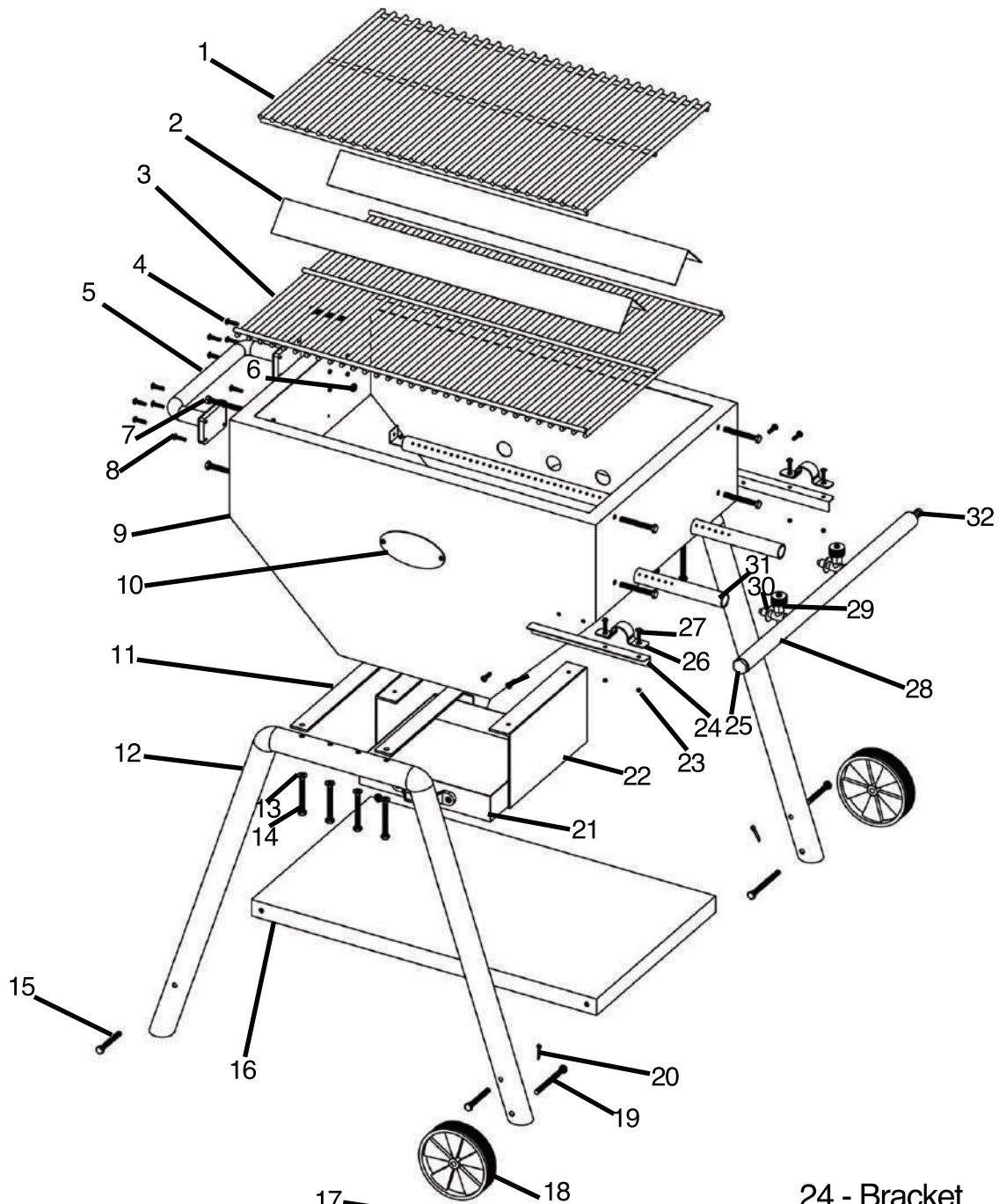

- |                       |                           |                        |                           |
|-----------------------|---------------------------|------------------------|---------------------------|
| 1 - SS Cooking Grates | 9 - Grill Body            | 16 - Platform          | 24 - Bracket              |
| 2 - Heat Shield       | 10 - Badge                | 17 - 6mm Nut (Wheel)   | 25 - End Cap              |
| 3 - Charcoal Grates   | 10 - 6mm Bolt For Leg     | 18 - Wheel             | 26 - Pipe Clip            |
| 4 - 4mm Handle Bolt   | 11 - Stability Bar        | 19 - 8x75 Bolt         | 27 - 4mm Bolt (Pipe Clip) |
| 5 - SS Lift Handle    | 12 - Leg                  | 20 - Split Pin (Wheel) | 28 - Gas Tube             |
| 6 - 6mm Nut (Grill)   | 13 - 6mm Washer           | 21 - Drip Tray         | 29 - Gas Tap              |
| 7 - 6x60 Bolt (Grill) | 14 - 6x60 Bolt (Leg)      | 22 - Drip Tray Holder  | 30 - Gas Tap Washer       |
| 8 - 4mm Burner Bolt   | 15 - 6x60 Bolt (Platform) | 23 - 4mm Nut           | 31 - Burner               |
|                       |                           |                        | 32 - Gas Nipple           |

Model name, part number with part name is necessary when ordering spare parts.

# Assembly Guide

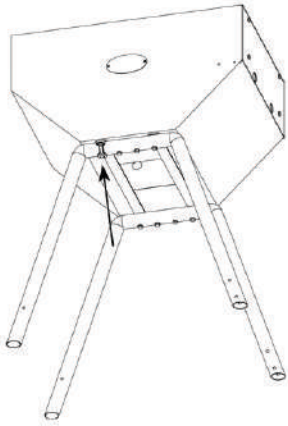

Step 1 - Fix the front and back legs accordingly by tightening the four 6mm bolt with washers, through wrench holding the nut on the other side through another wrench. First and last bolts will accommodate the stability bar in between as shown.

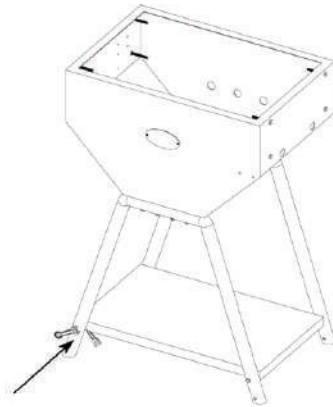

Step 2 - Fix the bottom platform by tightening the 6mm bolt through wrench holding the nut on the other side through another wrench on all 4 sides.

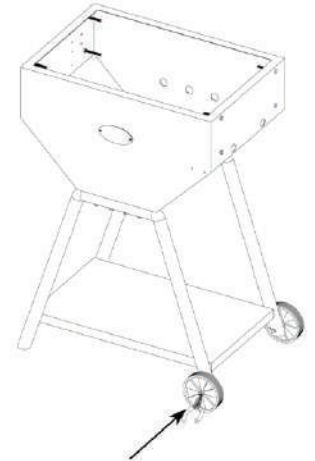

Step 3 - Insert the wheel to the leg on both side. Insert the pin to interlock the wheel. Bend the pin bottom through plier.

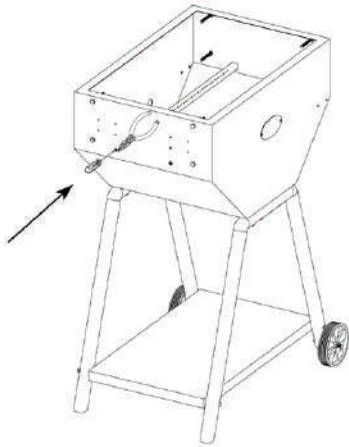

Step 4 - Fix the gas burner by tightening the screw, holding the nut through sharp nose plier.

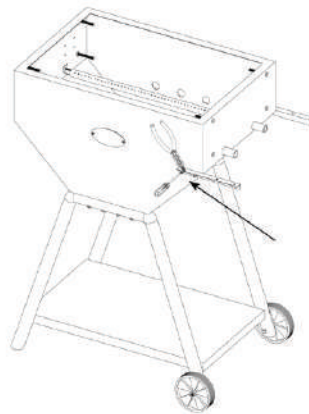

Step 5 - Fix the brackets through 2 screws on each side, holding the nut inside the grill body through plier.

⚠ Do Not Overtighten!



Step 6 - Fix the gas clip through 2 screws on each side by holding the nut through plier.

⚠ Part No. - 28 (Gas Tube), 29 (Gas Tap) & 32 (Gas Nipple) comes as single part. If one of them are removed or disconnected, stop assembling and contact supplier. Make sure the gas tap washer (P30) is inserted to Gas Tap (P29).

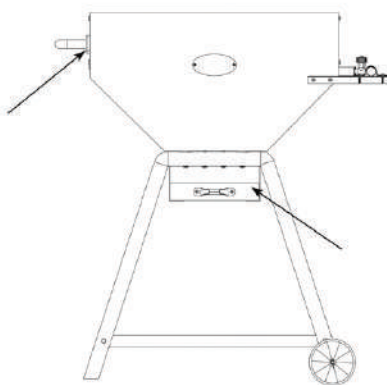

Step 7 - Fix the SS Lift Handle by tightening all eight 4mm bolts holding the nuts through sharp nose plier. Fix Drip Tray Holder by tightening the screw, holding the nut through plier. Insert the drip tray.

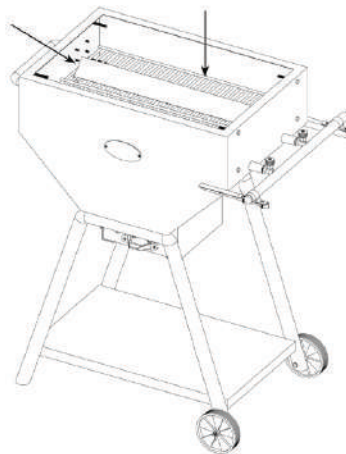

Step 8 - Insert the charcoal grates, top of the burner. **Horizontal rod side upwards (Arrow Mark).** Place the stainless steel heat shields on top of charcoal grates covering burner.

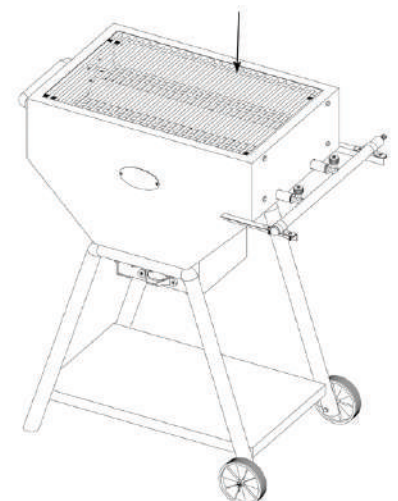

Step 9 - Place the stainless steel cooking grates on top of the grill.

## Assembled in 9 steps.

Tools Needed  
 - 10 Size Wrench (6mm) x 2  
 - 13 Size Wrench (8mm) x 2  
 - Philip Head Screw Driver  
 - Sharp Nose Plier  
 (Tools Not Provided)

# WARNING!



If you smell gas or hear a leaking noise shut off gas to the grill & call your supplier. (Failure to follow these instructions could result in severe injury, explosion, property damage or death.)



Do not store or use gasoline, alcohol or any other flammable liquids in the area surrounding the grill area.



Some parts may contain sharp edges. Wear protective gloves during operation.



The grill will be extremely hot during operation. Do not touch the surfaces of the grill while operation.



Minimum 1 inch gap between grill body and charcoal on all 4 sides are compulsory when charcoal grilling.



Do not let children under 16 years to operate this grill. Keep children and pets away from this machine at all times.



Never operate this grill unattended!



Never operate this grill within 10 feet of any structure, wall and etc. Never operate within 20 feet of any flammable liquid or materials.



If a fire occurs keep away from the grill and call your fire department.



**Wash the SS cooking grates before use!**  
Wash your hands after using this product!



Do not attempt to repair or alter any part of this product. Any modification to this assembly will revoke your warranty and create the risk of gas leaks and fire.



When grill not in use, Disconnect the gas cylinder!



Pre heat the grill for 10 minutes prior to use. Curing of coating will produce an odour on first time.



Clean the product more often. Do not wash using high pressure water. Wiping the surface through wet cloth, atleast 3 hours after usage is recommended. Make sure there are no bristles on the cooking grates before grilling.



If the flame is blocked in particular holes of the burner, use a pin to clean up the blocks in holes. If the burner is hard to light, remove the burner and clean inside. (Long Wire brush & Blower)



**Never use the grill indoor!** Always use it outdoor in a very well ventilated space.



Do not use high pressure gas regulator! Low pressure gas regulator is recommended.



The LP gas cylinder should never be stored in an area where temperature can reach 125°F. (51°C)



Do not ignite the burner using match sticks, paper or other materials. Use a BBQ lighter to ignite the burner.



If ignition doesn't occur in 5 seconds after switching on the gas control knob, remove the gas cylinder and contact the supplier.

# FOR OUTDOOR USE ONLY!

# STARTUP GUIDE

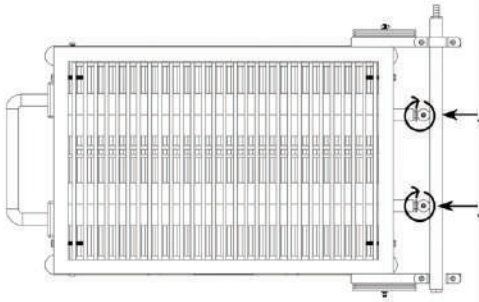

Step 1 - Make sure the gas valves are fully closed. (Clockwise)

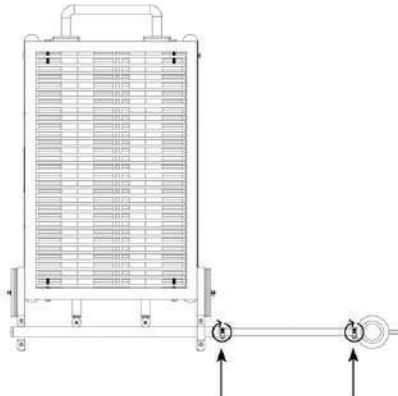

Step 2 - Insert the hose in gas inlet and regulator and tighten the hose clips on both side.



Step 3 - Connect the regulator to gas cylinder and switch on. (Rotate Clockwise)  
[Conventional Low Pressure Gas Regulator is Recommended]

**⚠ Do Not Use High Pressure Gas Regulator!**

## GAS GRILLING

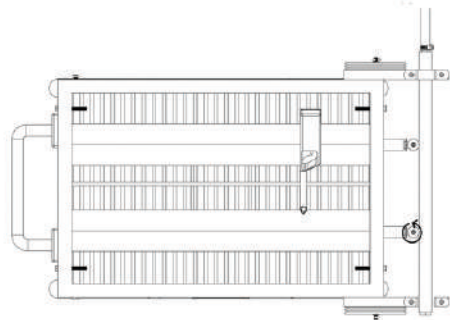

Step 4 - For Gas grilling, start the lighter, point towards the burner (Under SS Heat Shield) and open the gas valve slowly to ignite the burner. (Anticlockwise)  
Control the fire using gas valves.

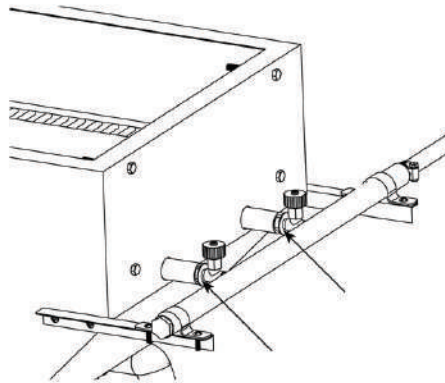

Step 5 - Release the washer valve away from the burner for more air intake, hence less carbon emission. (Flame Colour - Light Blue)

## CHARCOAL GRILLING

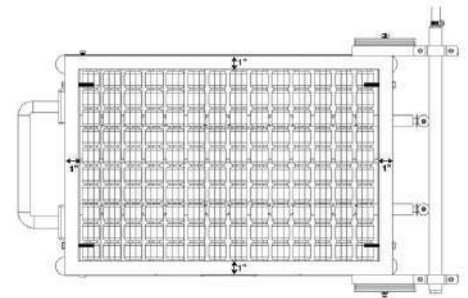

Step 6 - For Charcoal grilling, remove the SS heat shield and pour charcoal on the charcoal grates. (Black Grates) Avoid positioning the charcoal to the edge of the charcoal grates. 1" gap between body & charcoal is compulsory.

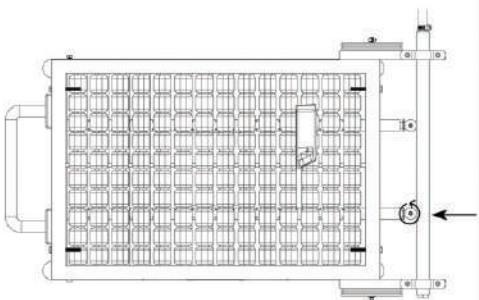

Step 7 - Start the lighter, point towards the burner and open the gas valve (anticlockwise) to ignite the burner. Charcoal will be lit by this method.

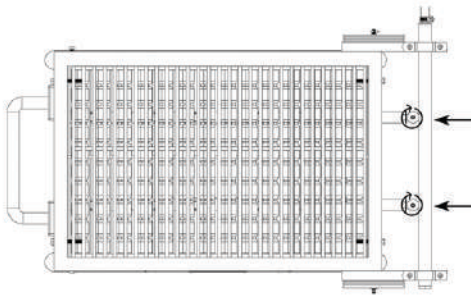

Step 8 - Once charcoal is lit or Gas grilling is finished, **Turn off the gas valve fully.** (Rotate Clockwise)

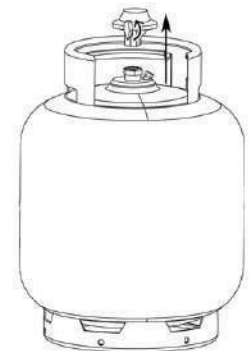

Step 9 - Remove the gas regulator from the Gas Cylinder.

# Grill Maintenance

- Allow the grill to cool before cleaning.
- When cleaning the grill, cover the area, brush out the residues and ash and wipe the body with wet cloth.
- SS Cooking grates may be cleaned with wire brush, rinse with water and air dry before cooking again. (make sure there's no loose bristles on the cooking grates after cleaning).
- Charcoal grates are exposed to direct heat and prone to rust. Use a wire brush to remove rust.
- Cook meat and poultry throughoutly to kill bacteria.
- Use a food thermometer to measure the meat temperature.
- Use a grill cover to cover the grill when it's exposed to extreme weather conditions. This will increase the life time of the grill.



Minimum gap of 1 inch between charcoal & grill body on all 4 sides are compulsory! (Charcoal Grilling)



Clean the meat drippings (fat) & charcoal ash from the machine, grates and grill body & Dispose the wastages from drip tray after each cooking. Failure to do so could cause a grease fire. (Extreme rise of flame height), Hence **discoloration of powder coating**.



Do not pour any liquid (liquor, alcohol, wine, drinks & etc.) inside the grill while grilling. This will cause explosion!

-Discoloration of burners & charcoal grates are common since they're exposed to direct flame.

# Grill Care & Use

# Limited Warranty

**This warranty only applies to units purchased from an authorized retailer.**

**A dated sales receipt WILL be required for warranty service.**

This limited warranty applies only to the functionality of the product and **does not cover** cosmetic issues such as dents, scratches, powder coating peel off, corrosions or discoloring by heat, abrasive and chemical cleaners or any tools used in the installation or assembly of the product, surface rust, or the discoloration of stainless steel surfaces. Powder coating is not warranted and will require touch up. **RUST** is not considered a manufacturing or materials defect.

**MANUFACTURER WILL NOT PAY FOR:**

1. Transport cost for warranty and replacement parts
2. Damage, failures, or operating difficulties resulting from accident, alteration, careless handling, misuse, abuse, fire, improper installation or maintenance, use of products for installation not approved by the manufacturer.
3. Any food loss due to product failures or operating difficulties.
4. Pickup and delivery of your product.
5. Repairs to parts resulting due to unauthorized modifications made to the product.
6. The removal or reinstallation of your product

Dealers, retailers or any others selling this product **do not have any authority** to make any additional warranties or promises in addition to or inconsistent with those stated above.

Manufacturer's maximum liability at any event, **will not exceed** the purchase price of the product paid by the original customer.

The warranty will expire, 3 years from the date of purchase.

# 3 Year Limited Warranty

Scan the QR code below to watch the video on Startup Guide.



YouTube Link -<https://www.youtube.com/watch?v=gzQxBEQvQDU>

**LANKA<sup>®</sup>**  
**GRILLS**

[www.lankagrills.lk](http://www.lankagrills.lk)  
[info@lankagrills.lk](mailto:info@lankagrills.lk)

© Designed and Manufactured by Lanka Grills.  
No.581, Negombo Road, Wattala.

©This product is protected under the National Intellectual Property Office of Sri Lanka.